

# KEM - Your Partner for Flow Measurement Technologies



DESIGN | PRODUCTION | DISTRIBUTION

Company profile .....	3
Flow meters .....	6-14
Gear flow meters (ZHM) .....	6
Turbine flow meters (HM) .....	8
Helical flow meters (SRZ) .....	10
Coriolis mass flow meters (TCM) .....	12
Micro flow meters (LFM) .....	14
Calibration laboratory .....	15
Impulse pickup systems .....	16-19
Compact and standard impulse amplifiers .....	17
Threaded pulse amplifiers .....	18
Remote impulse amplifiers .....	18
Local converters .....	19
Displays .....	20-21
Local displays .....	20
Battery powered local displays .....	20
Remote displays .....	21
Certifications .....	22
TASI Group .....	23
Contact .....	24

## KEM - MADE IN GERMANY

KEM Küppers Elektromechanik GmbH headquarters in Karlsfeld near Munich.

The following departments are located there:

- Mechanical Engineering
- Design
- Software Engineering
- Sales
- Accounting
- Human Resources
- Management
- Customer Support

KEM Küppers Elektromechanik GmbH  
Liebigstraße 5  
D-85757 Karlsfeld

T. +49 8131 59391-0

F. +49 8131 92604

info@kem-kueppers.com



Headquarters (Karlsfeld)



Manufacturing center (Bad Kötzing)

KEM Küppers Elektromechanik GmbH manufacturing center is located in Bad Kötzing.

The following departments are located there:

- Mechanical Manufacturing
- Electronic Manufacturing
- Assembly
- Repairs
- Quality Assurance
- DAkkS Calibration Laboratory
- Shipping
- Purchasing

KEM Küppers Elektromechanik GmbH  
Wetzeller Straße 22  
D-93444 Bad Kötzing

T. +49 9941 9423-0

F. +49 9941 9423-23

info@kem-kueppers.com

With our wide range of products, we can offer you a high quality solution for your flow application.

- Gear flow meters
- Turbine flow meters
- Helical flow meters
- Coriolis mass flow meters
- Micro flow meters



#### Special equipment

- State of the art CAD and FEM systems
- CNC milling and turning centers
- High precision calibration rigs

#### Our goals

- Customer satisfaction
- Innovative products
- Worldwide customer service
- Quality manufacturing
- Healthy growth

#### KEM - Your partner for reliable flow measurement technologies & demanding flow measuring tasks

With over 50 years of experience in the flow measurement field, complemented by innovative and customer-specific product development, we are your competent partner in the flow measuring technology and calibration.

KEM offers a wide range of measuring principles. We are a global supplier of premium quality gear, turbine, helical and micro flow meters. Coriolis mass flow meters round off the product range.

KEM Küppers Elektromechanik GmbH was founded in 1965, specializing in the field of flow measurement technology. We distinguish ourselves by our customized solutions for demanding measurement tasks in all industrial sectors.

As an independent manufacturer, we keep all design and manufacturing processes in our own hands at all times through our exceptionally high level of vertical integration. Thanks to significant investments in design, development and production, we provide 'Made in Germany' production quality.

#### Engineering and manufacturing

KEM's engineers use state of the art CAD and FEM systems for design and simulation. High-precision manufacturing and high flexibility in the implementation of specific customer requirements are distinguishing features of the KEM production site.

#### Quality management

The satisfaction of our customers is our top priority. Outstanding customer support and the continuous further development of our quality management system are therefore essential. KEM has been operating a quality management system certified according to DIN EN ISO 9001 since 1994. Environmental protection and occupational safety are defined in our documented processes along with special requirements for our products (ATEX, CSA, IECEx, EAC (TR-CU) etc.).

## Your flow application is our challenge

The exceptional service by KEM is based on professional, high-quality technical solutions oriented to the needs of the customer. Our sales and application engineers work closely with the customers to develop the best technical and economical solution for your measurement task.

Here are some of the examples:

- Unusual materials including Duplex and Hastelloy
- Special connection types
- High temperature applications
- High pressure applications
- Compact designs
- Lightweight designs
- OEM designs

Our in-depth knowledge and the ability to adapt our solutions to the specific requirements of the customer enables us to meet every challenge.

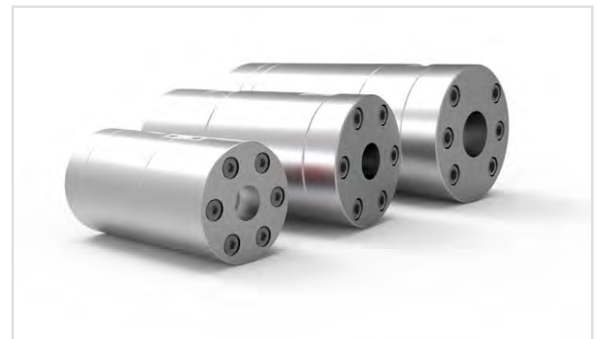

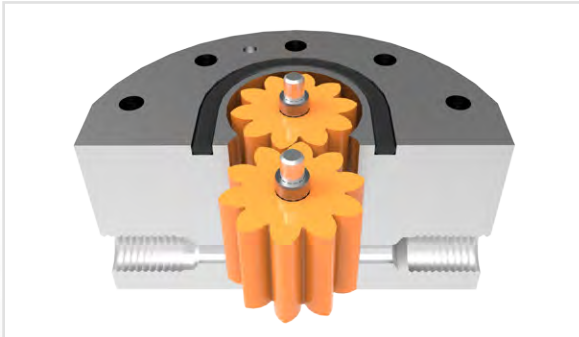

Sectional model



ZHM family



Special designs

**Automotive:**

- Paints and coating
- Corrosion protection
- Sealing and adhesives

**Hydraulics:**

- Test stands
- High pressure hydraulics
- Mobile hydraulics
- Cylinder distance measurement

**Process technology:**

- Mixing and dosing
- 2-component and 3-component applications
- Consumption measurement

**Oil and Gas industry:**

- Onshore and offshore
- Chemical injection
- Sub-sea hydraulics
- Flow assurance (methanol/MEG)

**Gear flow meters (ZHM)** are positive displacement meters. Two precise gears rotate freely inside the measuring chamber.

Sealed cavities are created between the gears and the housing. The measured media causes the rotation of the gears. The gear wheels rotate freely and undamped in the media flow. Their rotational frequency is proportional to the flow rate and is measured by non-intrusive pickups through the housing wall.

These meters are suitable for accurate measurement of different liquids with viscosities of approximately 1 to 25,000 mm<sup>2</sup>/s. If a wide measuring range needs to be covered, gear wheel flow meters with ball bearings are also used especially for low-viscosity media and fuels.

Thanks to a high output frequency, excellent resolution and short response times, our gear wheel flow meters are outstanding for measuring pulsing flows, for consumption measurement and for dosing of liquids.

For applications in hazardous areas, we offer intrinsically safe sensors and amplifiers with Ex protection in accordance with ATEX, IECEx, CSA and other standards. Additional certifications such as EAC (TR-CU) are available.

## Versions

- Tungsten carbide sleeve bearings
- Ball bearing version
- Flushing optimized design
- Light weight version
- Heating jackets
- Versions for hydraulics
- High pressure version
- OEM versions

## Technical Data

- Flow range: 0.002 - 1,000 l/min
- Viscosity range: 1 - 25,000 mm<sup>2</sup>/s
- Repeatability: <0.1 %
- Maximum pressure: up to 1,035 bar
- Temperature range: -40 up to +220 °C (-40 up to +428 °F)

## Fluid Types

- Water-based paints, two component paints, highly filled metallic paints and Softfeel paints
- Preservative waxes, adhesives, PVC, epoxy resins, filled and abrasive media
- Polyol and isocyanate
- Oils, fats
- Hydraulic oil and fuel

## Benefits

- Wide flow range
- Fast response time
- Pulse doubling and quadrature
- Stainless materials
- Corrosion-resistant design
- Applicable for electrostatic/ESTA applications

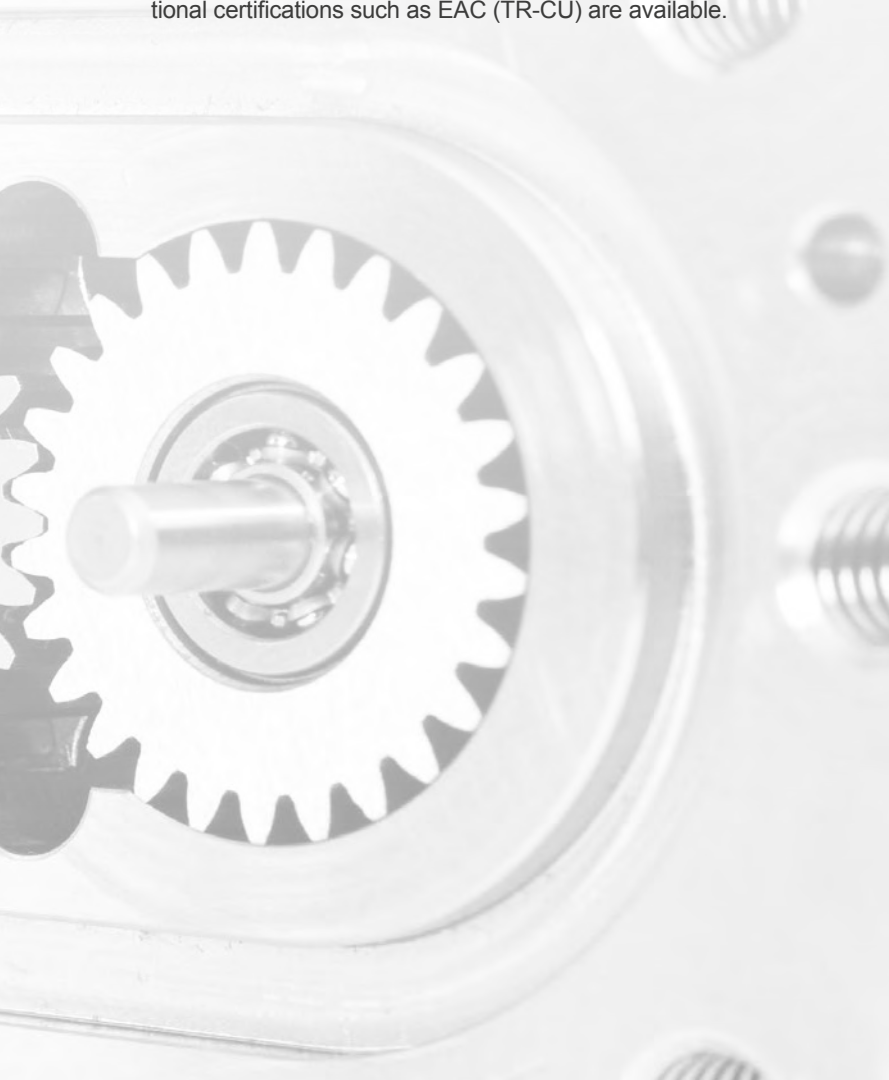



Sectional model



HM family



Special designs

**Temperature control technology:**

- Heating circuit monitoring
- Cooling circuit monitoring
- Energy balancing

**Energy:**

- Consumption measurement
- Condensate measurement
- Difference measurement

**Hydraulics:**

- Test stands
- High-pressure measurement
- Test vehicles
- Mobile test systems

**Water/cleaning:**

- Flow rate monitoring
- Solvent consumption
- Flushing media

**Oil and Gas industry:**

- Methanol and ethanol injection
- Subsea fluid control fluid/ROV
- Glycol/salt water/condensate measurement



**Turbine flow meters (HM)** are volume counters according to the Woltmann impeller counter principle. They capture the volume flowing through a pipe cross-section by means of the average flow rate.

A low mass turbine wheel is concentrically mounted in the tubular body of the turbine. The flowing medium hits it in the axial direction and rotates it. Flow conditioners smooth the flow, so that the wheel is in contact with a uniform flow profile. The speed of the turbine wheel is proportional to the average flow velocity in the pipe cross section and is therefore proportional to the flow rate.

Turbine flow meters are used for precise measurement of instantaneous flow rates and flow-metering of low viscosity liquids.

The KEM turbines feature a short response time between 5 and 50 ms depending on the nominal width, which is advantageous for precise filling processes.

Turbine flow meters have a resolution up to 100,000 pulses per litre. Thanks to milled and turned structural components, KEM turbine flow meters have no welding seams or solder points in contact with the media. The design of the turbine guarantees that rapidly changing flow rates are captured with precision.

For applications in hazardous areas, we offer intrinsically safe sensors and amplifiers with Ex protection in accordance with ATEX, IECEx, CSA and other standards. Additional certifications such as EAC (TR-CU) are available.

## Versions

- Pipe fitting
- Tri-Clamp mounting version
- Flange version
- High pressure version
- Aluminium version
- OEM versions

## Technical Data

- Flow range: 0.03 - 25,000 l/min
- Viscosity range: 0.6 - 100 mm<sup>2</sup>/s
- Repeatability: <0.1 %
- Maximum pressure: up to 4,000 bar
- Temperature range: -196 up to +350 °C (-321 up to +662 °F)

## Fluid Types

- Water (normal and demineralized water)
- Oils
- Fuels
- Solvents
- Liquefied gases and cryogenic liquids
- Pharmaceutical liquids

## Benefits

- High resolution
- Fast response time
- High pressure resistance
- Low pressure drop
- Resistant to contamination

Küppers GmbH  
065.71.FDB160-TC15-G  
100 - 2000 l/min  
11412220  
1.4571

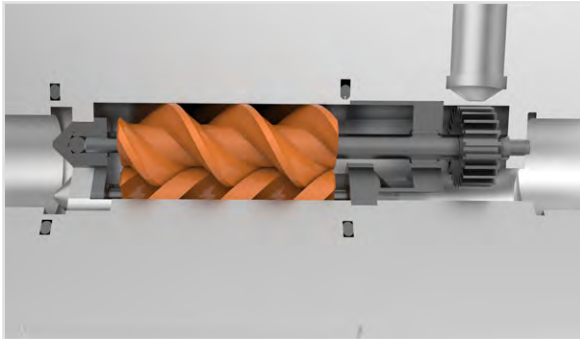

Sectional model

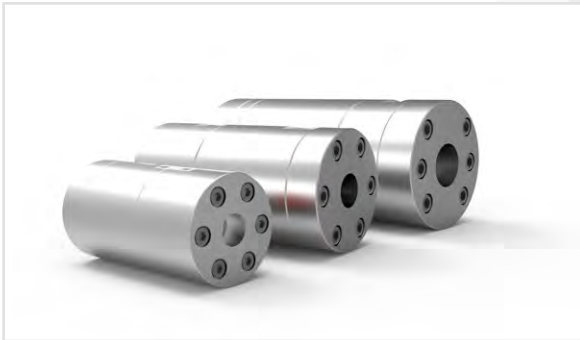

SRZ family



Special designs

**Automotive:**

- Seam sealing
- Underbody coating
- Gluing and sealing
- Coating

**Hydraulics:**

- Transmission test stands
- Lubricant monitoring
- Pump test stands
- Cylinder distance measurement

**Process technology:**

- Mixing and dosing
- 2-component and 3-component applications
- Glue dosing
- Consumption measurement

**Helical flow meters (SRZ)** are positive displacement meters with two cycloidal spindles with geometrically overlapping profiles. These profiles mesh in a cylindrical housing. This creates measuring chambers between the spindle profiles and the housing walls.

The flow of the measuring medium is forced axially through the spindle profiles along the two measuring chamber holes, which causes the spindles to rotate. This occurs without pulsation and with minimum leakage. Using an index gear with a high number of teeth the pickup detects the rotational speed of the spindle pair through the housing wall. The speed is proportional to the volume flow over a very wide range.

Due to their design helical flow meters are ideal for measuring high viscous liquids. Thanks to large measuring ranges, high accuracy and resolution along with low pressure loss, they are extremely well suited for lamination, painting, gluing and PUR systems as well as dosing systems for various media.

The devices are also insensitive to viscosity changes and pulsating flows, and enable pulsation-free measurement. Due to the high quality materials and bearing components used, KEM helical flow meters are extremely corrosion resistant.

For applications in hazardous areas, we offer intrinsically safe sensors and amplifiers with Ex protection in accordance with ATEX, IECEx, CSA and other standards. Additional certifications such as EAC (TR-CU) are available.

## Versions

- Tungsten carbide sleeve bearings
- Ball bearing version
- Compact version
- OEM versions

## Technical Data

- Flow range: 0.04 - 400 l/min
- Viscosity range: 1 - 1,000,000 mm<sup>2</sup>/s
- Repeatability: <0.1 %
- Maximum pressure: up to 400 bar
- Temperature range: -40 up to +150 °C (-40 up to +302 °F)

## Fluid Types

- Polyurethane and polymers
- Adhesives and sealants
- Heating oil
- Petrochemical products
- Thixotropic liquid
- Oils and fats
- Pastes

## Benefits

- High resolution
- High accuracy
- Wide measuring ranges
- Largely independent of viscosity
- Low pressure drop
- Non-sensitive to pulsating flows
- Resistant to corrosion by advanced materials and bearings
- Low operating noise



Compact version

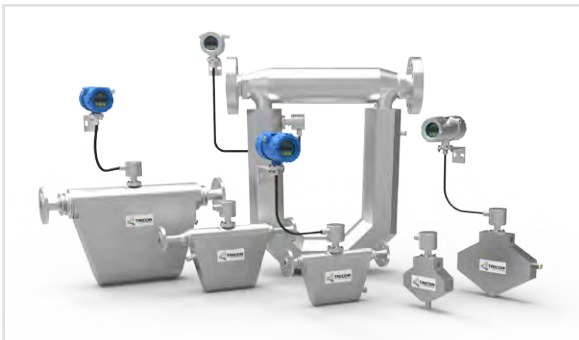

Remote version



High pressure version

**Automotive:**

- Two component (paints)
- Fuel test stands

**Marine:**

- Fuel consumption measurement

**Oil and Gas industry:**

- Oil/water cut
- Chemical injection
- Loading, unloading

**Chemistry:**

- Blending
- Loading, unloading
- Dosing

**Energy:**

- Fuels
- High-pressure hydrogen (fuel)



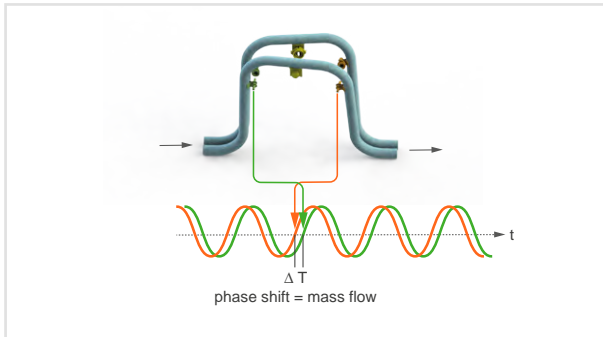

Principle of operation

Coriolis mass flow meters (TCM) operate with two parallel tubes with coils that cause them to oscillate at their resonance frequency. Should a measurement flow enter the measuring tube, Coriolis forces are the result. Coriolis forces appear in oscillating systems when a mass moves towards or away from a rotational axis. These forces act on the inlet and outlet side in the opposite direction and minimally deform the measuring tubes. The deflection of the measurement tubes is captured by sensors on the inflow and outflow side. These two sensors measure a phase shift that is proportional to the mass flow.

The resonance frequency of the tubes varies depending on the density of the medium to be measured. This effect is used to measure the density of the medium.

Since the elastic properties of the flow tubes depend on the temperature, a temperature measurement is carried out for compensation.

The primary characteristics such as mass flow rate, density and temperature are measured with a single flow meter. The volume flow can be determined based on the mass flow rate and density.

TCM is suitable for all kinds of liquids. It is particularly well suited for flow measurements of paints, chemicals, fuels and synthetic resin components.

For applications in hazardous areas, we offer versions with Ex protection according to ATEX, IECEx, CSA and other standards. Additional certifications such as type testing for marine use and EAC (TR-CU) are available.

### Versions

- Compact version
- Remote version
- High pressure version
- Electronics in stainless steel (1.4404)
- Special installation lengths (customer-specific)
- OEM versions

### Technical Data

- Flow range: 3 - 230,000 kg/h
- Density: 1 - 2,500 kg/m<sup>3</sup>
- Basic Accuracy: 0.1 % o.r.
- Maximum pressure: up to 1050 bar
- Temperature range: -60 up to +200 °C (-76 up to +392 °F)

### Fluid Types

- All types of liquids
- Non-conductive liquids
- Viscous liquids
- Gas flows (e.g. airflows)
- Pulps, media containing solids
- Fluid mixtures (oil/water)
- Two-component applications (paints)
- Hydrogen fuel measurement (up to 875 bar)

### Benefits

- Universal measuring principle for liquids and gases
- Simultaneous and direct measurement of mass flow rate, density and temperature
- Measuring principle that is independent of the physical characteristics of the material being measured
- Very high measuring accuracy
- Bidirectional measurement
- Independent of the flow profile
- No inlet and outlet zones required
- Flexible installation sizes available (customer-specific)



Sectional model



LFM

#### Technical Data

- Flow range: 0.005 - 0.25 l/min
- Viscosity: 0.6 - 5 mm<sup>2</sup>/s
- Repeatability: <0.1 %
- Maximum pressure: up to 100 bar
- Temperature: from -60 up to +180 °C (-76 up to +356 °F)
- High resolution

#### Fluid Types

- Additives
- Pharmaceuticals
- Odorant
- Tap water and demineralized water
- Liquified gases
- Solvents and hydrocarbons

**Micro-flow meters (LFM)** are based on a double ring piston pendulum. A pendulum movement of the two interconnected ring pistons is caused by the flowing liquid. Due to the low pendulum weight and minimal friction losses the LFM even responds to the smallest volume flows. The piston design additionally minimizes leakages and guarantees good linearity and repeatability.

The LFM is a flow meter for low viscosity liquids of all kinds used in dosing and filling operations. It can be used for extremely low flow rates from 0.005 l/min with high resolution.

For applications in hazardous areas, we offer intrinsically safe sensors and amplifiers with Ex protection in accordance with ATEX, IECEx, CSA and other standards.

#### Food technology:

- Sterilization
- Dosing

#### Process technology:

- Low volume measurement
- Additive dosing
- Odorising
- Consumption measurement



## The DAkkS calibration laboratory

The KEM calibration lab, accredited to the international DIN EN ISO/IEC 17025:2005 standard, uses a high-precision load cell system. The KEM calibration lab is one of the best in the world with accuracies of 0.05 % for mass and 0.1 % for the volume of liquid flow.

The laboratory with engineers, processes and calibration equipment was audited by the DAkkS, the notified body of Germany to approve calibration lab's according to the DIN EN ISO/IEC 17025:2005 standard. The KEM calibration rig operates on the highest technical level. A unique feature is the ability for calibrations to be done on various hydrocarbons. This enables simulation of various densities, viscosities and even temperatures to match the application operating conditions.

A certificate from KEM not only verifies the accuracy of a flow meter, but also guarantees its traceability to national standards. The advantage for the customer is, that all requirements by international quality standards are met.

## DAkkS accreditation

- Viscosities: up to 100 mm<sup>2</sup>/s
- Volume flows: 0.016 to 2,000 l/min
- Accuracy: 0.05 % - 0.1 % of actual flow

## KEM standard calibration

- Volume flows: 0.002 up to 20,000 l/min
- Viscosities: up to 3,000 mm<sup>2</sup>/s

## Services

- Calibration certificate
- Calibration for different viscosities
- Flow rates up to 20,000 l/min
- Third party calibration

## KEM standard calibration

We conduct calibrations to provide calibration records with precise details on min./max. frequency, K-factor (lmp/l) and linearity. On request calibrations for additional viscosities and reverse flow direction are available.

## Benefits

- Highest calibration accuracy
- Traceability to national standards
- International accepted results and documentation
- Quick turn around time for calibrations



DAkkS calibration laboratory

To capture the rotational movement, KEM offers pickups with various sensors that are optimized for the different flow meters.

*(These don't apply to Coriolis mass flow meters).*

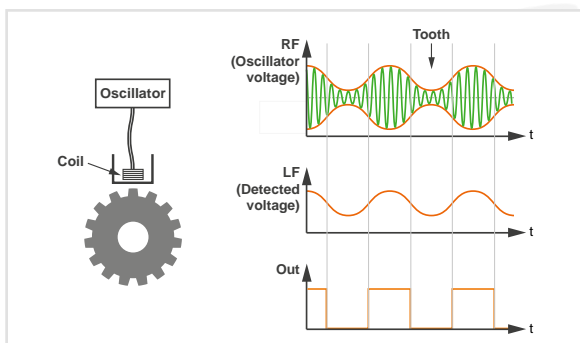

Principle of operation: Carrier frequency

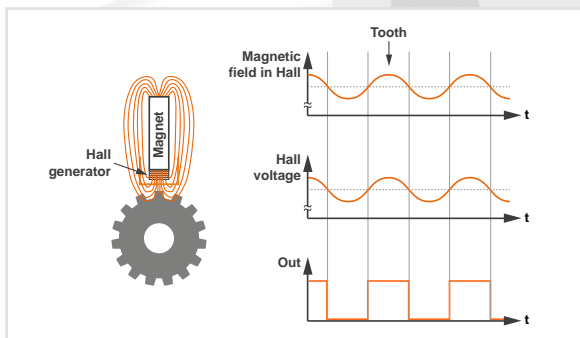

Principle of operation: Hall

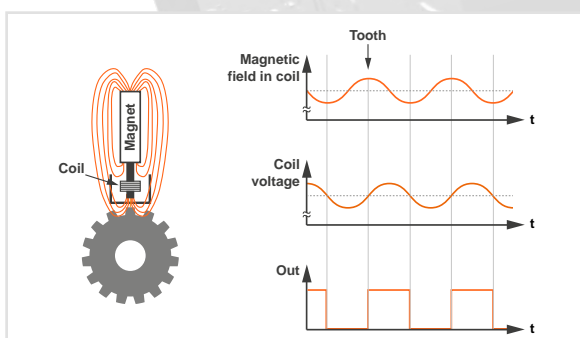

Principle of operation: Inductive

**Carrier frequency:** An oscillating magnetic field is damped by the teeth of a gear wheel or the turbine blades. The frequency of the carrier's resulting amplitude modulation corresponds to the rotational speed of the wheel and therefore indicates the flow rate. The output signal of the pickup is amplified, modified and output as current or voltage rectangular pulses. With a broad frequency range (approx. 0.5 Hz to approx. 5 kHz), interference resistance and low power input carrier frequency measuring elements are among the standard sensors for stainless steel measuring cells.

**Hall:** A weak magnetic field is deflected by the gear wheels or turbine blades, thereby altering the output signal of a Hall generator.

The output signal of the Hall generator is amplified, modified and output as current or voltage rectangular pulses. The frequency of the output signal corresponds to the flow rate.

These pickups have a broad frequency range (approx. input frequency 1 Hz to more than 5 kHz) and feature good interference resistance. Hall sensors are also suitable for flow meters with aluminium housings.

**Inductive:** A weak magnetic field is deflected by the movement of the gear wheels, turbine blades etc. and thereby induces a voltage in a coil. The frequency range is between 7 and 3,000 Hz. The frequency of the output signal corresponds to the volume flow. Inductive sensors have a very low power input.

Inductive pickups are particularly well suited for high temperatures up to +350 °C (+662 °F) and battery-powered applications. They can also be used with aluminium housing measuring cells.



The non-intrusive **compact and standard pulse amplifiers** capture the rotational speed of the KEM flow meters.

These usually compact and pluggable units can even be integrated directly in the flow meter. High-resolution systems that recognise the flow direction are available. Pulse amplifiers with optical outputs are also used for electrostatic systems in painting applications.

### Technical Data

- Medium temperature: up to +80 °C (+176 °F)
- Frequency range: 0.5 - 5,000 Hz
- Frequency output: Push Pull, Open Collector or NAMUR
- Ex protection in accordance with ATEX, IECEx, CSA and other standards



Compact pulse amplifiers

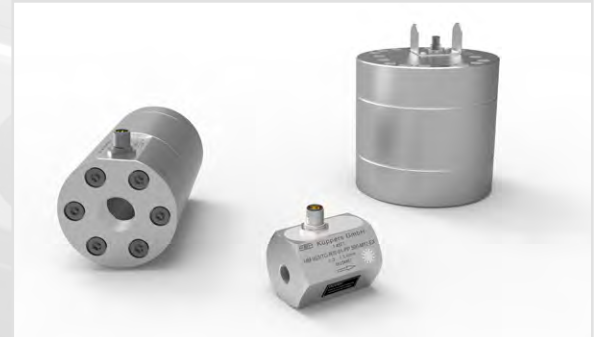

Integrated pulse amplifiers



Pulse amplifiers for electrostatic systems with optical signal transmission



**Technical Data**

- Medium temperature: up to +150 °C (+302 °F)
- Frequency range: 0.5 - 5,000 Hz
- Frequency output: Push Pull, Open Collector or NAMUR
- Ex protection in accordance with ATEX, IECEx, CSA and other standards



VTE02 and VIES

Non-intrusive **threaded pulse amplifiers** capture the speed of the KEM volume meters.

They are threaded (M14 x 1.5) for installation in nearly all KEM flow meters and measure flow rates at medium temperatures up to +150 °C (+302 °F). The thread makes for straightforward replacement of the pulse amplifier in just a few steps.

**Technical Data**

- Medium temperature: -196 up to +350 °C (-321 up to +662 °F)
- Frequency range: 7 - 3,000 Hz
- Frequency output: Push Pull, Open Collector or NAMUR
- Ex protection in accordance with ATEX, IECEx, CSA and other standards



IFK-HTK, IFK, IS-L, IF with VIEG

Non-intrusive **remote pulse amplifiers** capture the speed of the KEM flow meters.

The inductive pickup coil and the amplifier unit are isolated from each other and interconnected by a cable. This enables flow measurements at very low and very high medium temperatures.

The pickup coil outputs a sine wave-form voltage signal in the mV range that is processed by the separate amplifier unit.

**Local converters** are passive 4 - 20 mA 2-wire pickup systems.

They are intelligent amplifiers that convert the pulse signal into an analog and pulse output with linearisation.

In addition to the analog output signal, a galvanically isolated open-collector output is available, which can be used either as a switching or frequency output. The frequency output is freely scalable. This means the frequency output can be scaled to the flow rate regardless of the flow meter.

With an interface adapter and the "KEM EasyControl" programming and visualization software, the converter can be configured accordingly via an integrated interface and an integrated data logger can be used.

Both the analog and the frequency output can be linearised with up to 20 points, which can greatly improve the measuring accuracy.

A remote version is also available for high medium temperatures up to +350 °C (+662 °F).



### Technical Data

- Medium temperature: -196 up to +350 °C (-321 up to +662 °F)
- Frequency range: 0.5 - 5,000 Hz
- Frequency output: Push Pull, Open Collector freely scalable, switching output
- Analog output: 2 wire 4 - 20 mA
- Linearisation
- Ex protection in accordance with ATEX
- Datalogger function



WT.02/WI.02

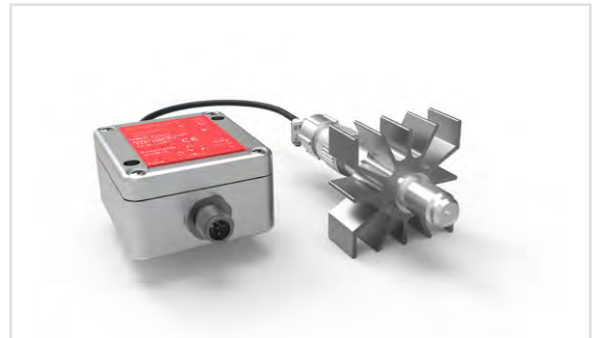

IFK-HTK with WIE-P3



CON.USB-WT interface adapter

### Technical Data

- Medium temperature: up to +240 °C (+464 °F)
- Frequency range: 0.5 up to 5,000 Hz
- Frequency output: Push-Pull, NAMUR, switching output
- Analog output: 4 - 20 mA
- Control input
- 20-point linearisation with three different linearisation curves
- USB or HART interface
- Ex protection in accordance with ATEX and IECEx



VTG, VIG and VTC

### Technical Data

- Medium temperature: up to +125 °C (+257 °F)
- Frequency range: 0.5 - 5,000 Hz
- Battery life: typically 5 years
- Aluminium housing for standard applications
- Stainless steel housing for offshore applications

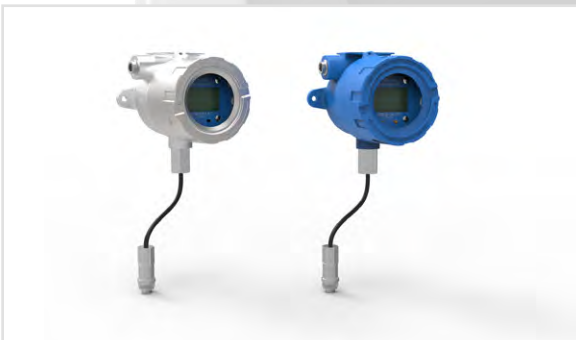

VTB

The VTG/VIG and VTC **local displays** consist of a measuring element, converter unit and display.

All units feature a graphical display, intuitive user guidance, adjustable 4 - 20 mA analog output and frequency output. As the engineering units can be freely selected, the display can be adapted to any measuring device and application.

Additional features include 20-point linearisation, control input and output for filling applications, limit monitoring and a built-in interface.

The units can be operated either in a 2-wire (4 - 20 mA passive) or in a 3-wire mode.

The "KEM EasyControl" programming and visualization software is available for simple laboratory test applications and rapid changes to the various parameters.

For applications in hazardous areas, we offer the VTG/VIG and VTC with Ex protection in accordance with ATEX.

The **VTB** are **battery powered local displays** for displaying flow rate and total amount.

Flow or total amount are displayed on a large, clear LCD display.

As the engineering units can be freely selected, the display can be adapted to any measuring device and application.

For applications in hazardous areas, we offer this display unit with Ex protection in accordance with ATEX and IECEx.

The FAS100/FAW100 are **displays** for control panel installation or wall mounting to be used in combination with pulse amplifiers.

All devices feature a graphical display, intuitive user guidance, adjustable 4 - 20 mA analog output and freely scalable frequency output. As the engineering units can be freely selected, the display can be adapted to any measuring device and application.

Optional features include 20-point linearisation, control inputs and outputs for filling applications as well as limit monitoring and a built-in RS485 interface.

The "KEM EasyControl" programming and visualization software is available for simple laboratory test applications and rapid changes to the various parameters.

### Technical Data

- Frequency output: Push-Pull
- Analog output: 4 - 20 mA
- Switching output
- Control input
- 20-point linearisation with three different linearisation curves
- RS485 interface



FAS100 with VTE02 and FAW100

P  
ERR  
FAS 100

Reset

Display

Info

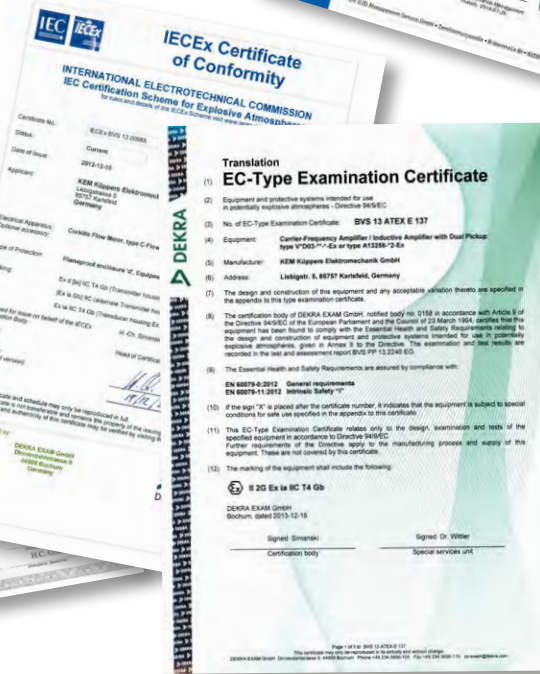

### A strong global network

KEM Küppers Elektromechanik GmbH is part of the TASI group.

The TASI group of companies is comprised of three business areas commonly linked by a disciplined focus on test, inspection and flow measurement. TASI flow products are designed, developed and manufactured through technical centers in the US, China, Switzerland, Germany and UK.

Calibration and service centers in Europe, Asia and the US allow us to provide full service and application expertise next to the customers door. Our customers take advantage of our strong global flow solution network with competence in a diverse lineup of flow measurement technologies.





Küppers Elektromechanik GmbH

[www.kem-kueppers.com](http://www.kem-kueppers.com)

[info@kem-kueppers.com](mailto:info@kem-kueppers.com)

#### KEM Headquarter

Liebigstraße 5  
85757 Karlsfeld  
Deutschland

T. +49 8131 59391-0  
F. +49 8131 92604

[info@kem-kueppers.com](mailto:info@kem-kueppers.com)

#### KEM Manufacturing Center

Wetzeller Straße 22  
93444 Bad Kötzing  
Deutschland

T. +49 9941 9423-0  
F. +49 9941 9423-23

[info@kem-kueppers.com](mailto:info@kem-kueppers.com)

#### KEM Service & Repairs

Wetzeller Straße 22  
93444 Bad Kötzing  
Deutschland

T. +49 9941 9423-0  
F. +49 9941 9423-23

[info@kem-kueppers.com](mailto:info@kem-kueppers.com)

*More distributors & partners can be found at:  
[www.kem-kueppers.com](http://www.kem-kueppers.com)*