



- Features :
 - Universal AC input / Full range
 - Built-in active PFC function
 - Protections: Short circuit / Overload / Over voltage / Over temperature
 - 5"x3" compact size
 - Free air convection for 100W and 150W with 20.5 CFM forced air
 - Medical safety approved (2 x MOPP between primary to secondary)
 - With power good and fail signal output
 - No load power consumption under 0.75W by PS-ON control (G model)
 - Standby 5V@0.8A with fan, @0.6A without fan (G model)
 - Suitable for BF application with appropriate system consideration
 - 3 years warranty

G: With 5Vsb & no load power consumption < 0.75 W RPD **G** - 160B
Blank: Basic function (without 5Vsb)



SPECIFICATION

MODEL		RPD-160B	
OUTPUT	OUTPUT NUMBER	CH1	CH2
	DC VOLTAGE	5V	24V
	RATED CURRENT (20.5CFM)	12A	3.6A
	CURRENT RANGE (convection)	1 ~ 6A	0.2 ~ 2.8A
	CURRENT RANGE (20.5CFM)	1 ~ 12A	0.2 ~ 3.6A
	RATED POWER (convection) Note.7	100.2W	
	RATED POWER (20.5CFM) Note.8	150.4W	
	RIPPLE & NOISE (max.) Note.2	80mVp-p	200mVp-p
	VOLTAGE ADJ. RANGE	CH1: 5 ~ 5.5V	
	VOLTAGE TOLERANCE Note.3	± 2.5%	± 6.0%
	LINE REGULATION	± 0.5%	± 1.0%
	LOAD REGULATION	± 1.5%	± 3.0%
SETUP, RISE TIME	1800ms, 30ms/230VAC	3500ms, 30ms/115VAC at full load	
HOLD UP TIME (Typ.)	16ms/230VAC/115VAC at full load		
INPUT	VOLTAGE RANGE Note.6	90 ~ 264VAC	127 ~ 370VDC
	FREQUENCY RANGE	47 ~ 63Hz	
	POWER FACTOR (Typ.)	PF>0.93/230VAC	PF>0.98/115VAC at full load
	EFFICIENCY (Typ.)	84%	
	AC CURRENT (Typ.)	1.7A/115VAC	0.9A/230VAC
	INRUSH CURRENT (Typ.)	COLD START 35A/115VAC 70A/230VAC	
LEAKAGE CURRENT Note.9	Earth leakage current < 200µA/264VAC , Touch current < 100µA/264VAC		
PROTECTION	OVERLOAD	105 ~ 135% rated output power Protection type : Hiccup mode, recovers automatically after fault condition is removed	
	OVER VOLTAGE	CH1: 5.75 ~ 6.75V Protection type : Shut down o/p voltage, re-power on to recover	
	OVER TEMPERATURE	TSW1: Shut down o/p voltage, recovers automatically after temperature goes down TSW2: Shut down o/p voltage, re-power on to recover	
FUNCTION	5V STANDBY (G model)	5VSB : 5V@0.6A without fan, 0.8A with fan 20.5CFM ; tolerance ± 2%, ripple : 50mVp-p(max.)	
	PS-ON INPUT SIGNAL (G model)	Power on: PS-ON = "Hi" or " > 2 ~ 5V" ; Power off: PS-ON = "Low" or " < 0 ~ 0.5V"	
	POWER GOOD / POWER FAIL	500ms>PG>10ms	PF>1ms
ENVIRONMENT	WORKING TEMP.	-20 ~ +70°C (Refer to "Derating Curve")	
	WORKING HUMIDITY	20 ~ 90% RH non-condensing	
	STORAGE TEMP., HUMIDITY	-40 ~ +85°C, 10 ~ 95% RH	
	TEMP. COEFFICIENT	± 0.03%/°C (0 ~ 50°C)	
	VIBRATION	10 ~ 500Hz, 2G 10min./1cycle, 60min. each along X, Y, Z axes	
SAFETY & EMC (Note 4)	SAFETY STANDARDS	ANSI/AAMI ES60601-1, TUV EN60601-1 approved	
	ISOLATION LEVEL	Primary-Secondary: 2xMOPP, Primary-Earth:1xMOPP, Secondary-Earth:1xMOPP	
	WITHSTAND VOLTAGE	I/P-O/P:4KVAC I/P-FG:2KVAC O/P-FG:1.5KVAC	
	ISOLATION RESISTANCE	I/P-O/P, I/P-FG, O/P-FG:100M Ohms / 500VDC / 25°C / 70% RH	
	EMC EMISSION	Compliance to EN55011 (CISPR11), EN55022 (CISPR22) Class B, EN61000-3-2,-3	
OTHERS	EMC IMMUNITY	Compliance to EN61000-4-2,3,4,5,6,8,11, EN55024, EN60601-1-2, EN61204-3, medical level, criteria A	
	MTBF	196.3K hrs min.	MIL-HDBK-217F (25°C)
	DIMENSION	127*76.2*34.6mm (L*W*H)	
	PACKING	0.33Kg; 36pcs/12.9Kg/0.79CUFT	
NOTE	1. All parameters NOT specially mentioned are measured at 230VAC input, rated load and 25°C of ambient temperature. 2. Ripple & noise are measured at 20MHz of bandwidth by using a 12" twisted pair-wire terminated with a 0.1µf & 47µf parallel capacitor. 3. Tolerance : includes set up tolerance, line regulation and load regulation. 4. The power supply is considered a component which will be installed into a final equipment. All the EMC tests are been executed by mounting the unit on a 360mm*360mm metal plate with 1mm of thickness. The final equipment must be re-confirmed that it still meets EMC directives. For guidance on how to perform these EMC tests, please refer to "EMI testing of component power supplies." (as available on http://www.meanwell.com) 5. HS1,HS2 & HS3 can not be shorted. 6. Derating may be needed under low input voltages. Please check the derating curve for more details. 7. The rated power includes 5Vsb @ 0.6A. 8. The rated power includes 5Vsb @ 0.8A. 9. Touch current was measured from primary input to DC output.		

Mechanical Specification

Unit:mm

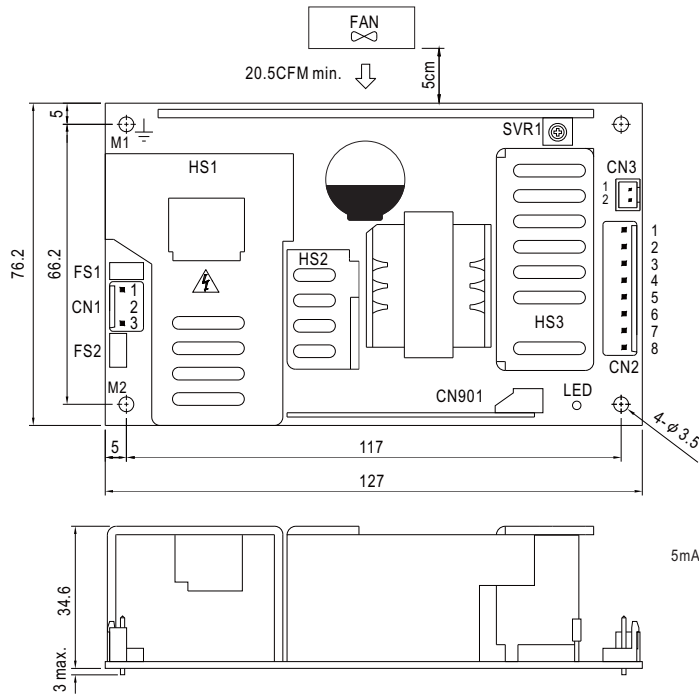

AC Input Connector (CN1) : JST B3P-VH or equivalent

Pin No.	Assignment	Mating Housing	Terminal
1	AC/L	JST VHR or equivalent	JST SVH-21T-P1.1 or equivalent
2	No Pin		
3	AC/N		

DC Output Connector (CN2) : JST B8P-VH or equivalent

Pin No.	Assignment	Mating Housing	Terminal
1,2,3,4	COM	JST VHR or equivalent	JST SVH-21T-P1.1 or equivalent
5,6	CH1		
7	CH2		
8	NC		

Power Good Connector(CN3):JST B2B-XH or equivalent

Pin No.	Status	Mating Housing	Terminal
1	PG	JST XHP or equivalent	JST SXH-001T-P0.6 or equivalent
2	GND		

5VSB Connector(CN901) : JST B-XH or equivalent

Pin No.	Assignment	Mating Housing	Terminal
1	PS/ON	JST XHP or equivalent	JST SXH-001T or equivalent
2,4	GND		
3	5VSB		

- 1.HS1,HS2,HS3 can not be shorted
- 2.M1 and M2 are Safety ground and should all be grounded.

Block Diagram

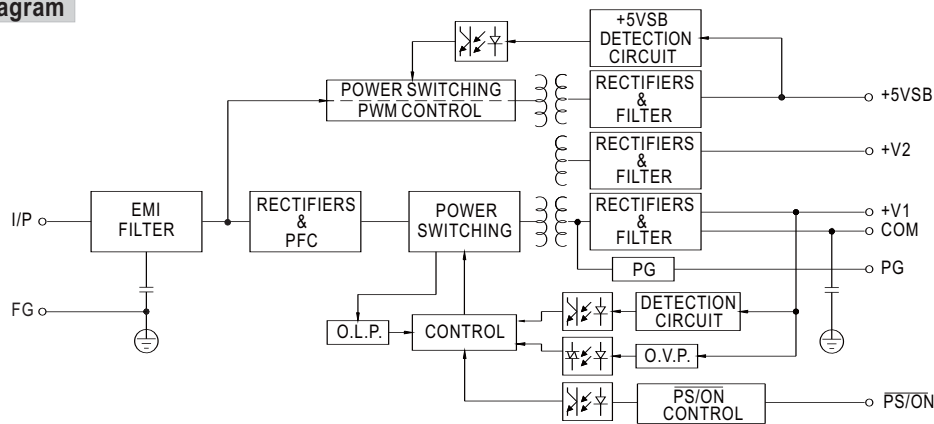

fosc :100KHz

Derating Curve

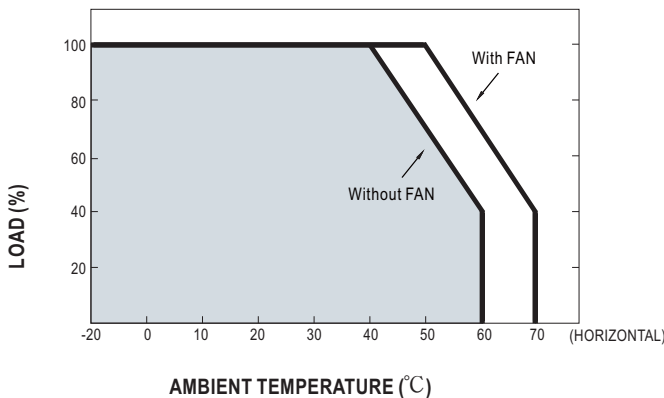

Output Derating VS Input Voltage

